

NELSON™ HEAT TRACE ES CONDUIT ENTRY SEAL

INSTALLATION INSTRUCTIONS

DESCRIPTION

The ES Conduit Entry Seal provides a watertight entry into a enclosure with minimum NEMA 3R environmental ratings. This fitting is suitable for use with any approved enclosure with a maximum wall thickness of 4.76mm (.1875") or with 1/2" NPT threaded openings. This kit is designed for use with all wattages of Nelson Heat Tracing Systems LT, CLT and HLT heater cables.

KIT CONTENTS

- 1 Conduit Entry Seal, 1/2" thread
- 1 Grommet, Heating Cable

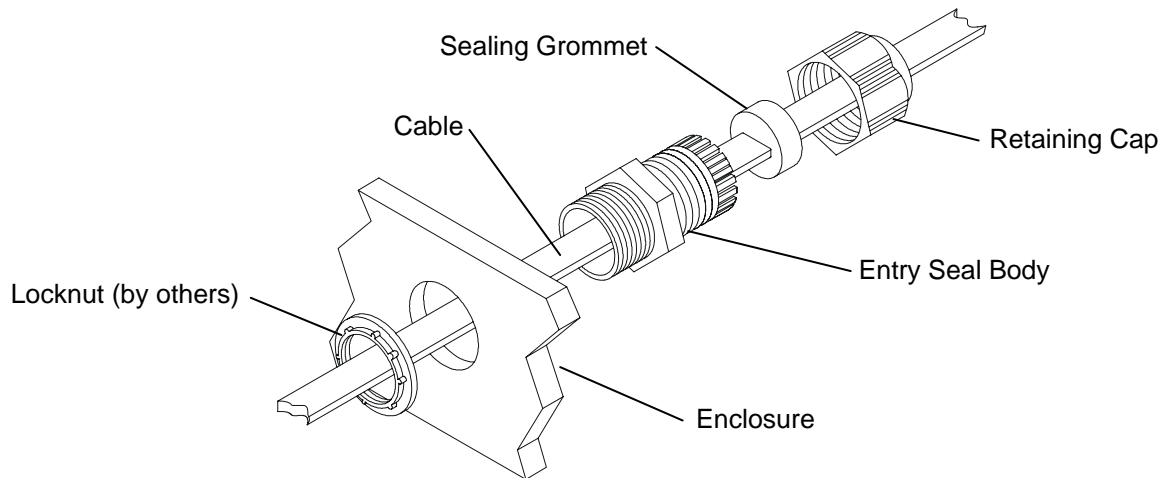

Note: This gland fitting is suitable for use with any approved enclosure with a maximum wall thickness of 4.76mm (.1875") or any enclosure with 1/2"NPT tapped cable entries.

1. Install entry seal body on selected enclosure. For enclosures without threaded hubs, install the connector and secure with the locknut (provided by others) as shown in the diagram above.
2. Slide the retaining cap over the end of cable to be terminated.
3. Insert the cable through the grommet/entry seal body and into the enclosure allowing enough cable to complete termination of the cable.
4. Tighten retaining cap securely to entry seal body. To avoid possible leaks, be careful not to over-tighten.
5. Terminate heating cable per manufacturers instructions. Cable terminations are not included in this kit.

Nelson Heat Tracing Systems products are supplied with a limited warranty. Complete Terms and Conditions may be found on Nelson's website at www.nelsonheaters.com.